

Surgical Technique

Pelvic C-Clamp

Pelvic C-Clamp Permits Reduction and Stabilization of the Posterior Pelvic Ring

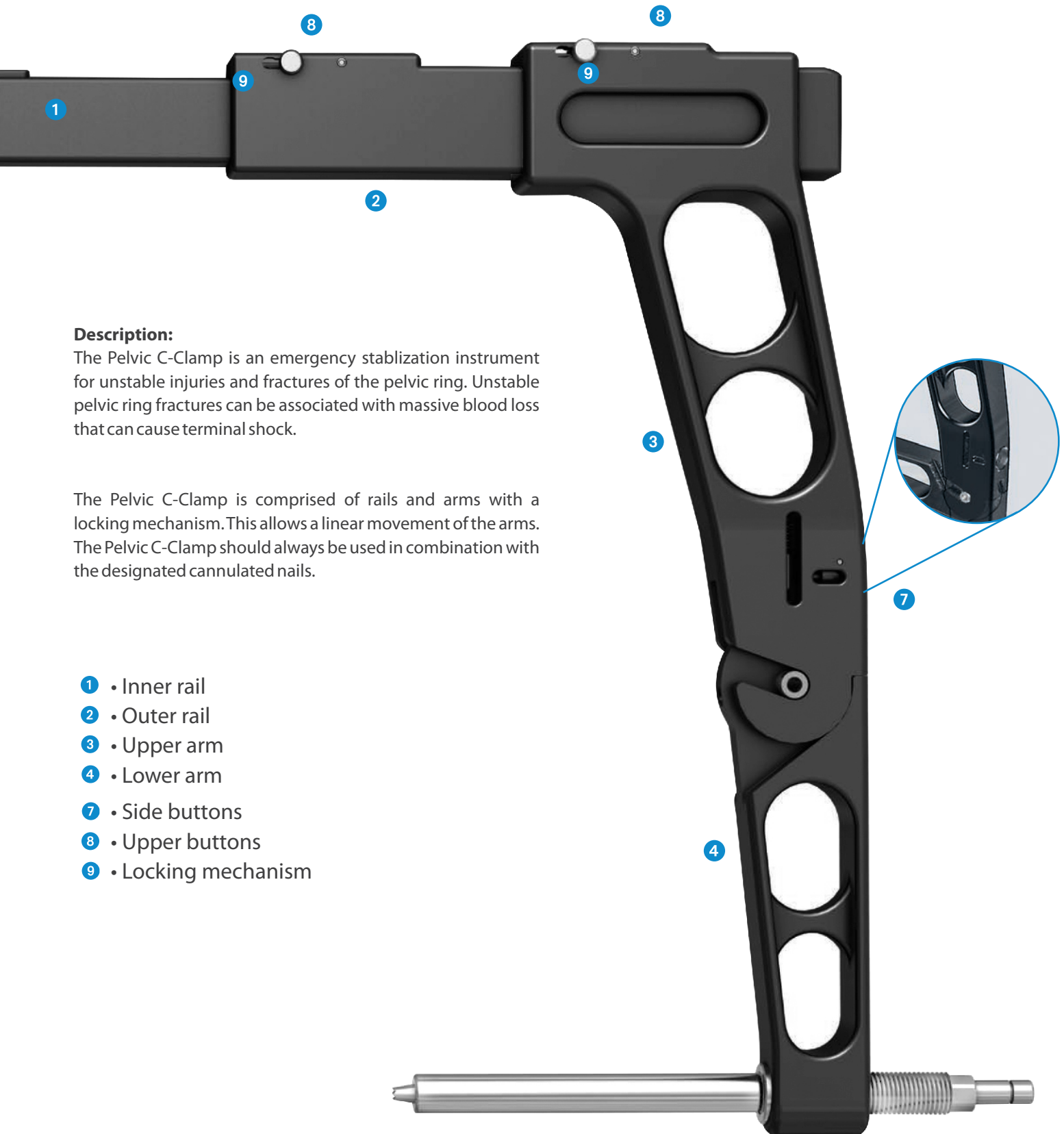

Description:

The Pelvic C-Clamp is an emergency stabilization instrument for unstable injuries and fractures of the pelvic ring. Unstable pelvic ring fractures can be associated with massive blood loss that can cause terminal shock.

The Pelvic C-Clamp is comprised of rails and arms with a locking mechanism. This allows a linear movement of the arms. The Pelvic C-Clamp should always be used in combination with the designated cannulated nails.

- 1 • Inner rail
- 2 • Outer rail
- 3 • Upper arm
- 4 • Lower arm
- 7 • Side buttons
- 8 • Upper buttons
- 9 • Locking mechanism

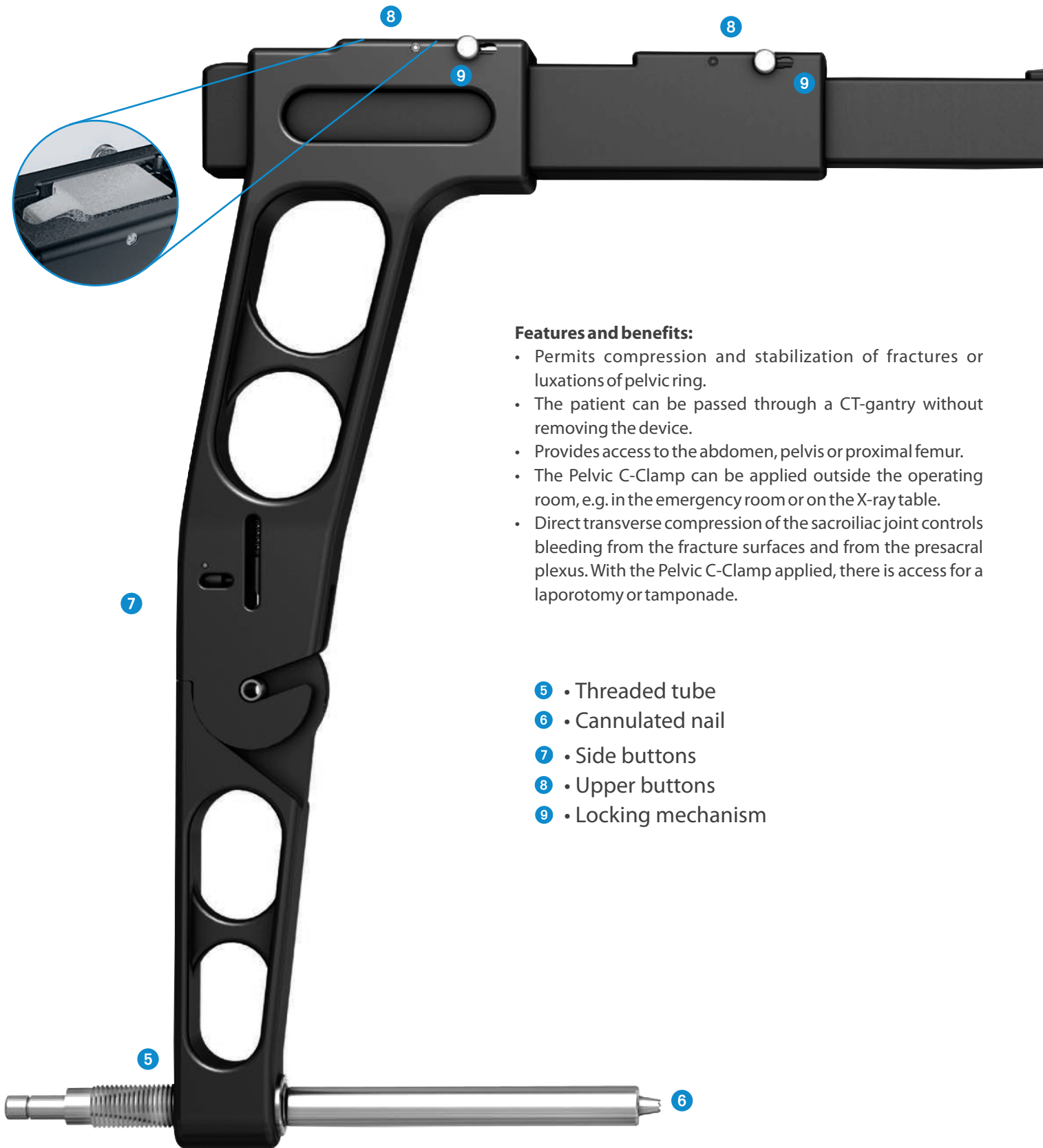

Features and benefits:

- Permits compression and stabilization of fractures or luxations of pelvic ring.
- The patient can be passed through a CT-gantry without removing the device.
- Provides access to the abdomen, pelvis or proximal femur.
- The Pelvic C-Clamp can be applied outside the operating room, e.g. in the emergency room or on the X-ray table.
- Direct transverse compression of the sacroiliac joint controls bleeding from the fracture surfaces and from the presacral plexus. With the Pelvic C-Clamp applied, there is access for a laparotomy or tamponade.

- 5 • Threaded tube
- 6 • Cannulated nail
- 7 • Side buttons
- 8 • Upper buttons
- 9 • Locking mechanism

Indications and Contraindications

Indications:

The Pelvic C-Clamp is indicated for emergency stabilization of sacrum fractures or disruptions of the sacroiliac joints with associated circulatory instability.

Precaution: Avoid use where:

- Fractures of the ilium are present as there is risk of pin perforation through the fracture line
- There are comminuted sacral fractures with the risk of compression of the sacral nerve plexus

Contraindications

No specific contraindications.

Note: In life threatening situations hemorrhage control takes priority over the potential risk of nerve root compression.



1. Pre-operative preparation

The Pelvic C-Clamp set consists of the instruments and implants for the emergency treatment of the indicated fracture types. The bottom layer of the Vario Case houses the Pelvic C-Clamp and the optional pliers. The upper layer houses the cannulated nails in two lengths and the remaining instruments.

The complete sterile Pelvic C-Clamp set should be kept ready for use in the resuscitation room. Depending on the type of injury, the orientation points in the pelvic region of the injured person may be unclear. Should there be doubts about the anatomic references, use an image

- intensifier during application of the Pelvic-C-Clamp.

Pre-operative preparation:

- Anteroposterior (AP) plain pelvic radiograph if necessary, oblique views (Inlet and Outlet) or CT.
- Patient positioning must allow for intraoperative fluoroscopic controls in AP, Inlet and Outlet Projections.
- Have an image intensifier available.

Positioning:

- Place the patient in a supine position.
- To facilitate reduction, ensure free draping of the leg on the injured side. Strive for good draping coverage of the genital region.
- To prepare the patient, disinfect the proximal femur and the buttocks and cover with sterile sheets.

Preparation of the Pelvic C-Clamp

Open the lower side arms by depressing the buttons on the arms to prepare the Pelvic C-Clamp for use. (a)

Note: Hold upper and lower arms with both hands and ensure that the lower arm is locked when fully extended.

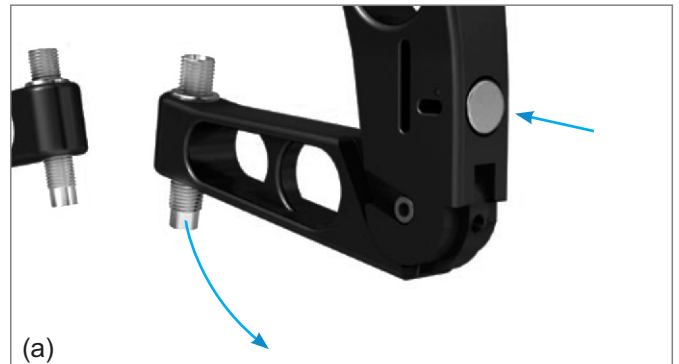

Extend the upper bars by depressing the buttons on the upper rails while simultaneously pulling on the side arms. (b)

Note: Maximal extension of the Pelvic C-Clamp is advantageous for easy positioning.

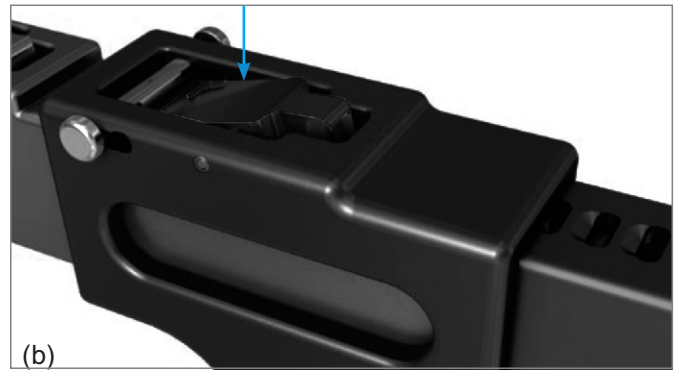

With a light twist, place the cannulated nails of preferred length into the threaded tubes. (c) The teeth on the tip of the nail allow for grip onto the bone.

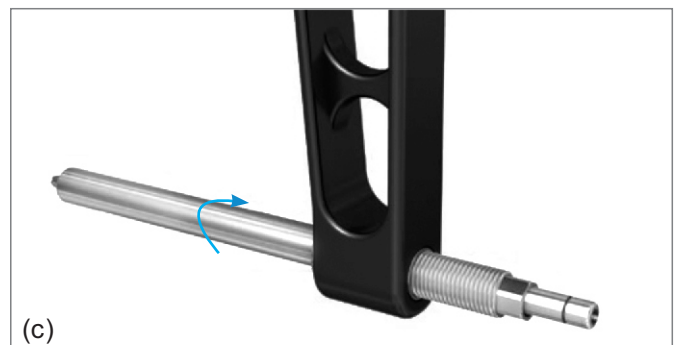

The buttons on the top of the Pelvic C-Clamp can be locked. Ensure the buttons are not locked when applying the Pelvic C-Clamp to the patient, otherwise no or insufficient compression can be achieved.



1 Unlock
2 Lock

2. Identifying nail insertion point

Make an incision at the intersection between the extension of the line of the femoral axis over the tip of the greater trochanter, and a vertical line from the anterior superior iliac spine in the dorsal direction (see illustration).

•If orientation is difficult, use an image intensifier.

The surface reference point of the outer side of the ilium changes at the level of the sacroiliac joints. In emergency situations, the resulting “fossa” can be used as a relatively secure point of reference aid. For secure anchoring, the Pelvic C-Clamp must be placed at the level of the sacroiliac joints.

Warning:

- If the nails are placed too ventrally to the correct insertion point, there is a risk of perforation of the ilium, which can result in organ injury.
- Placement of the pins in an excessively dorsal position may result in injury to gluteal nerves and vessels.
- Inserting the nail too distally endangers the sciatic nerve and the gluteal vessels in the sciatic notch. Malpositioning of the nail in osteoporotic bone, combined with excessive compression, can result in unwanted nail penetration.

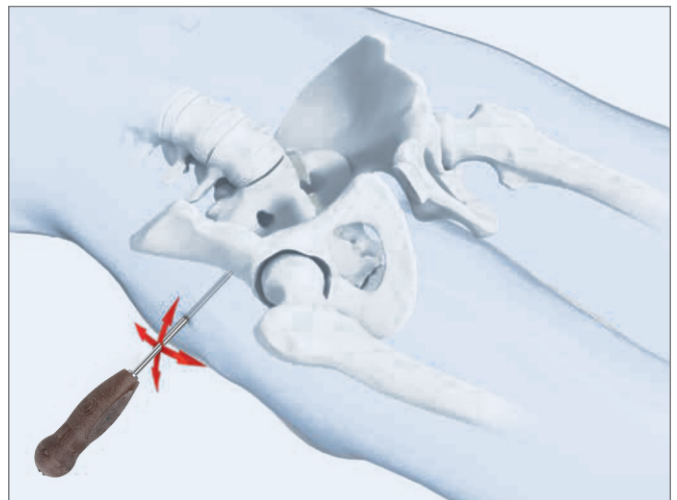
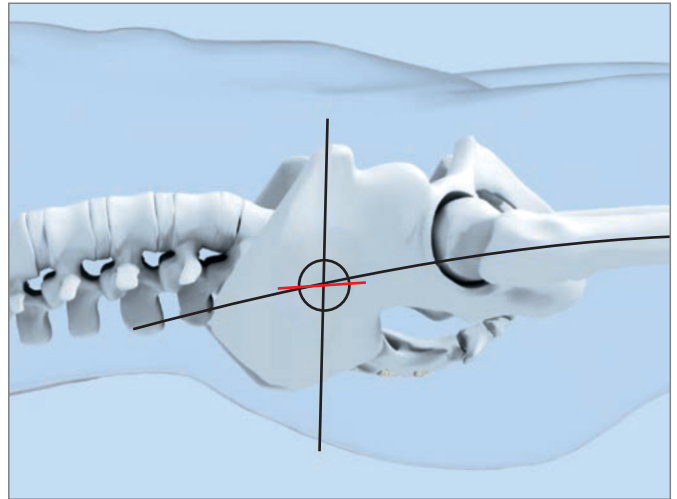

3. Kirschner Wire placement

After having identified the insertion point, a Kirschner Wire can be placed through the Guide Handle (only on the uninjured side). Gently hammer the Kirschner Wire into the bone with the Socket Wrench with Hammer. This Kirschner Wire will ensure an exact placement of the cannulated nail and prevents the nail from slipping.

Note: Malpositioned Kirschner wires can be removed with the optional pliers.

Precautions:

- Instruments and screws may have sharp edges or moving joints that may pinch or tear user’s glove or skin.
- Handle devices with care and dispose worn bone cutting instruments in an approved sharps container.
- Select the appropriate Schanz screw for the patient’s bony anatomy.

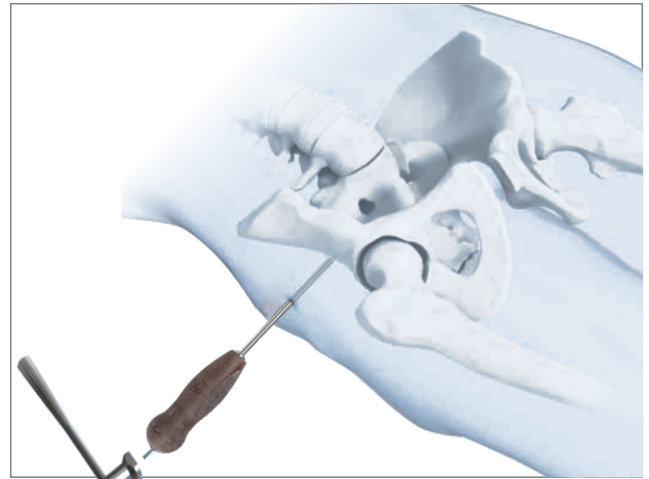

4. Placement of the Pelvic C-Clamp

Be sure the fracture is correctly reduced before placement of the Pelvic C-Clamp.

After inserting the Kirschner Wire on the uninjured side, slide the clamp with cannulated nails over the wire and ensure that the tip of the nail grips the bone securely. Then place the second nail on the injured side (no Kirschner wire is necessary on this side).

Note: In cases of severe dislocations of the pelvis, pulling on the leg, internal rotation and even lateral compression may improve reduction and facilitate application of the Pelvic C-Clamp.

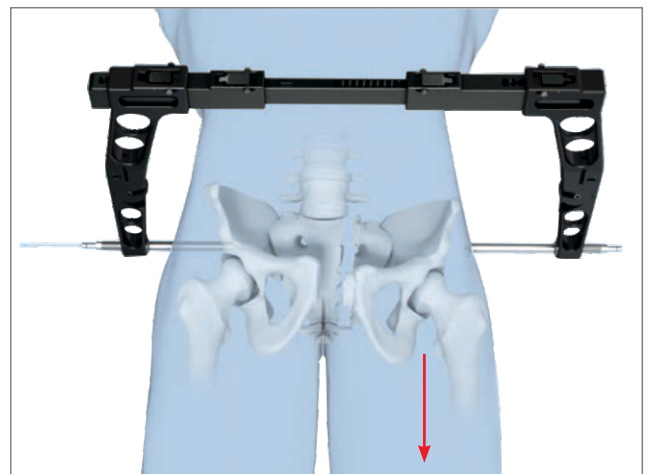
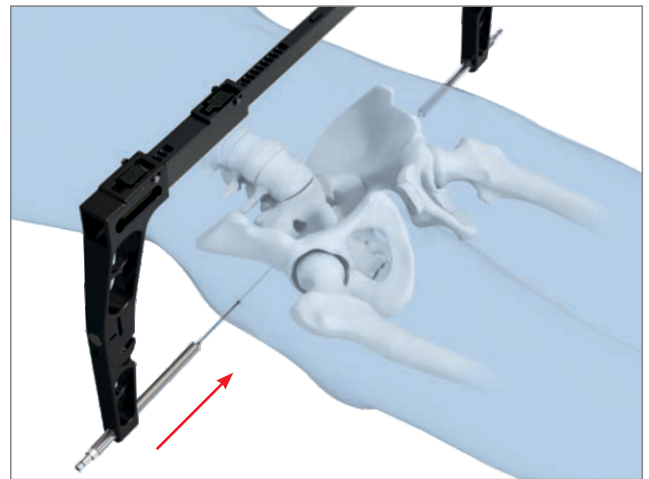

Alternative: Both nails can be placed at the same time. To do this take off one side arm. After both nails have been seated properly the arm can be placed over the rail again and compression can be achieved as described below.

When both nails are correctly seated, manually compress the upper side arms (a) and ensure final fixation by tightening the threaded tubes with the Ratchet Wrench (b).

The Kirschner wire must be removed with the wire cutter. If desired, place a protective cap on each end of the two cannulated nails.

- After complete application of the Pelvic C-Clamp, verify fixation with an image intensifier or X-ray (pelvic AP view) and pad the nails.

Note: The locking mechanism locks the upper buttons, thus preventing unintended loss of compression during movement of the Pelvic C-Clamp.

Once mounted, the Pelvic C-Clamp can be swung caudally and cranially, e.g. for a laparotomy or an angiography.

Note: It is recommended to place a drape cloth or lap sponges as a cushion between the Pelvic C-Clamp and the patient.

Warning: Do not use the Pelvic C-Clamp to lift the patient.

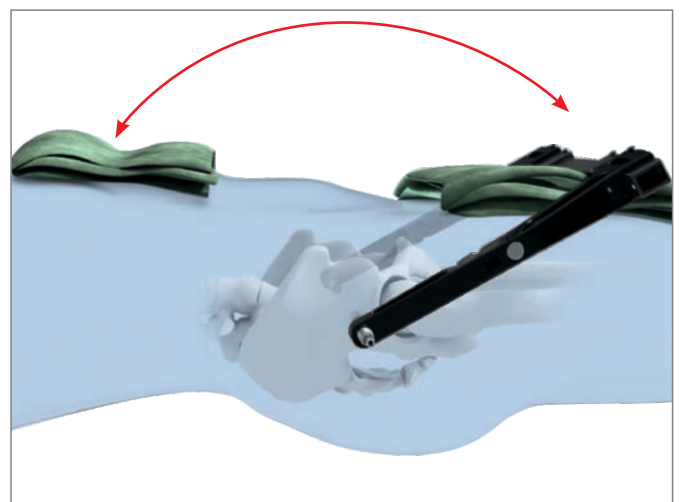
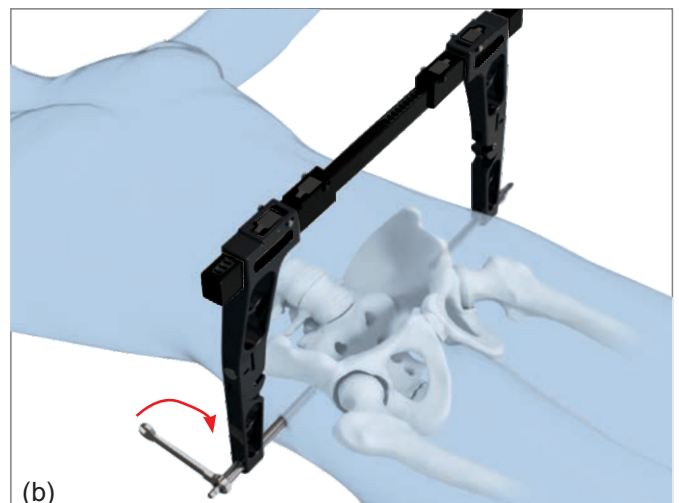
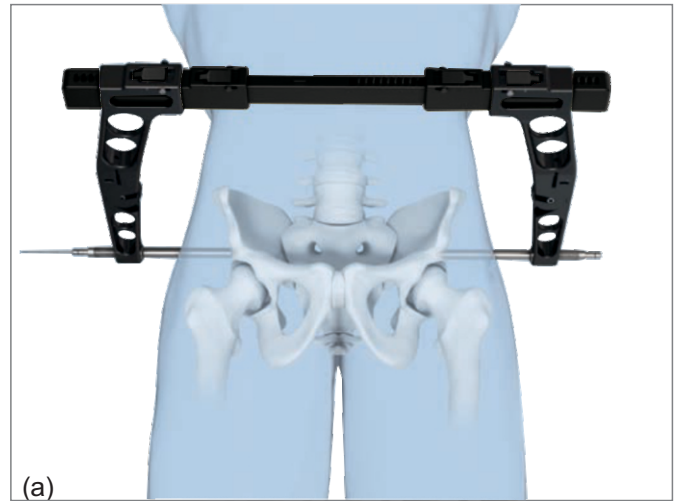

5. Postoperative management

- AP plain radiograph, CT if required, rarely oblique view films after application of Pelvic C-Clamp and during follow-up.
- Do not use the Pelvic C-Clamp to lift the patient.
- Wound closure; extended incisions may require a coapting skin suture.
- Continuing injury management according to polytrauma protocols.
- The nail insertion sites must be meticulously disinfected and dressed.
- Avoid turning the patient sideways as this could cause one of the nails to penetrate the bone excessively.

6. Removal

The Pelvic C-Clamp must be removed prior to definitive treatment of the posterior pelvic ring injury. Be sure to remove protective caps from cannulated nails and Kirschner wire from uninjured side.

Disassembly of the Pelvic C-Clamp

Note: Before cleaning, the Pelvic C-clamp should be disassembled.

The lower arms can be raised (2) by pressing the side buttons (1) as depicted by the red arrows.

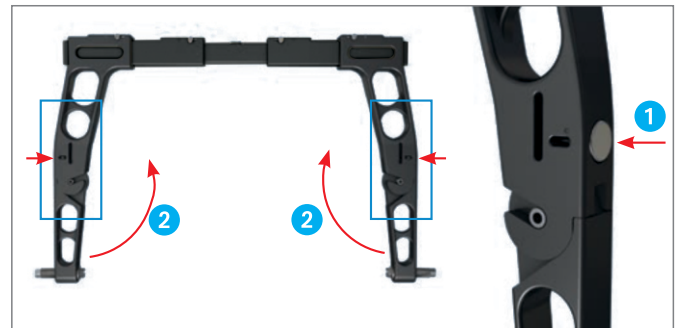

To remove the lower arms completely, keep pushing the buttons (1) and slide the arms out (2).

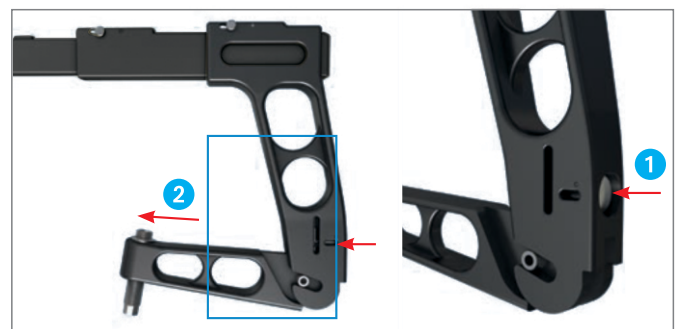

Unscrew the threaded tubes from the lower arms.

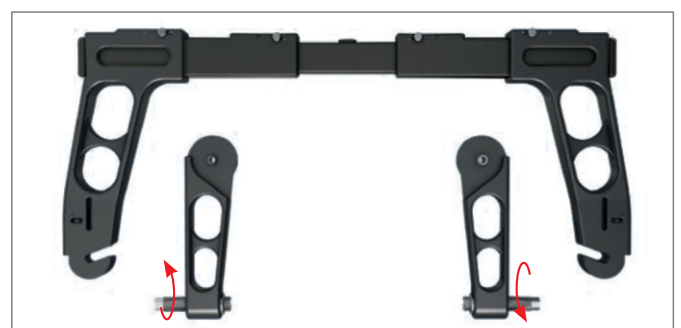

Before removing the upper arms from the upper rails, make sure the locking mechanism is unlocked (1). The upper arms can then be removed by pressing the top buttons (2) while simultaneously pulling on the arms (3). Be sure to hold the rails during this procedure to prevent the rails from falling.

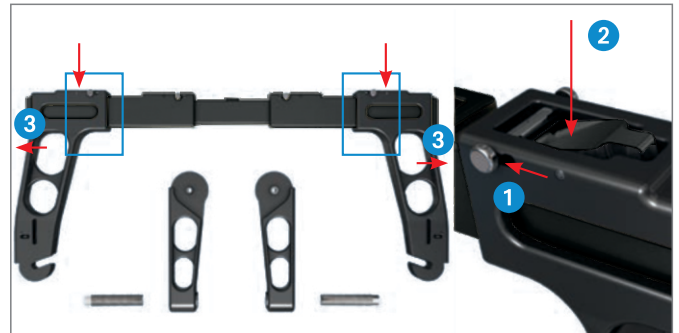

The outer rails can be separated from the inner rail by pressing the buttons on the outer rails and pulling the two rails apart (3).

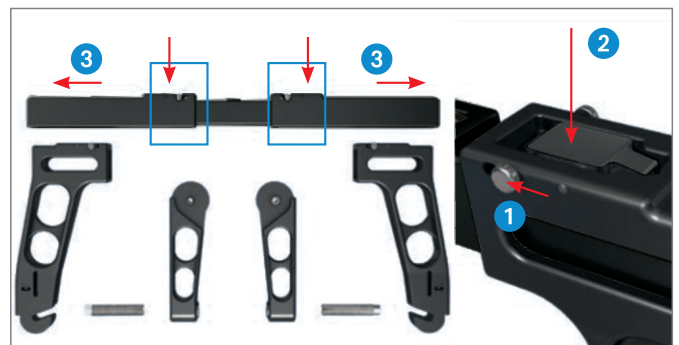

After disassembly, clean the rails, arms and threaded tubes manually, e.g. by using a brush. The springs in the upper arm at button should be cleaned too. If necessary, broken or damaged parts should be exchanged.

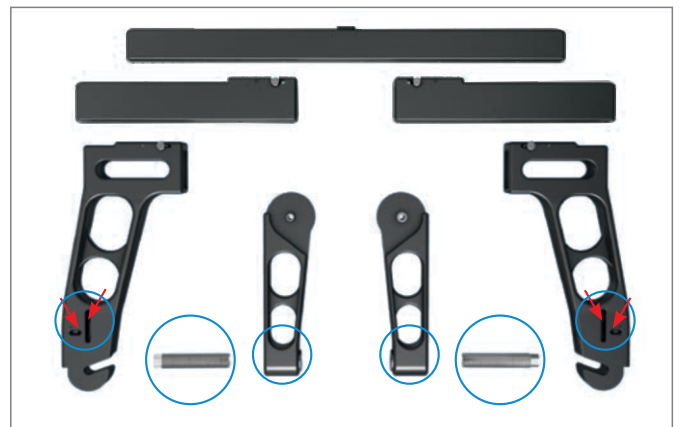

After cleaning, oil the thread of the threaded tube as well as the two holes next to the side buttons. The Pelvic C-Clamp should be checked after every use/ cleaning/sterilization to confirm correct function, i.e. that all parts move freely as intended. The complete sterile Pelvic C-Clamp should be kept ready for use in the resuscitation room. Due to the fact that the Pelvic C-Clamp consists of stainless steel, aluminum and a few pieces of polymer, it should only be cleaned at temperatures below 140°C and at a pH level between 7 and 9.5 (detergents).

Note: The cannulated nails are only for single use.

7-037-01

Pelvic C-Clamp Arm

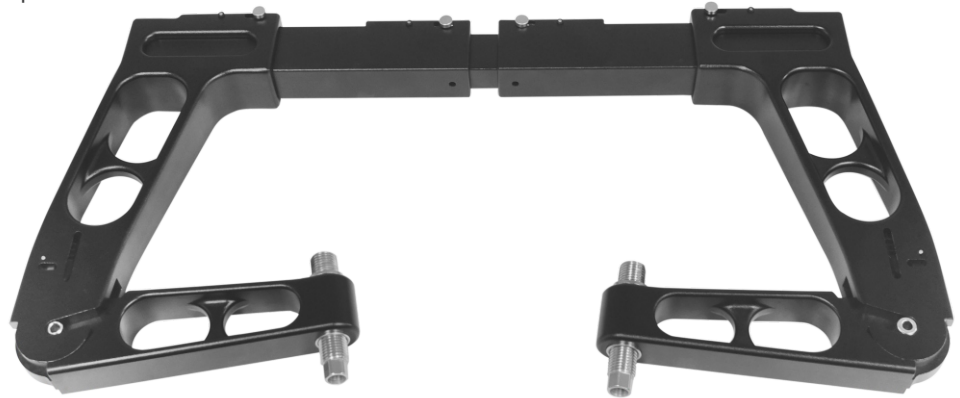

7-037-02

Nail for Pelvic C-Clamp, Cannulated, Long

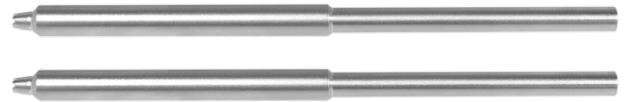

7-037-03

Nail for Pelvic C-Clamp, Cannulated, Short

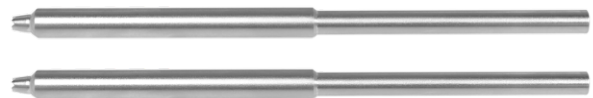

7-037-04

Kirschner Wire with One Sided Trocar Tip Ø2.5mm x Length 280mm

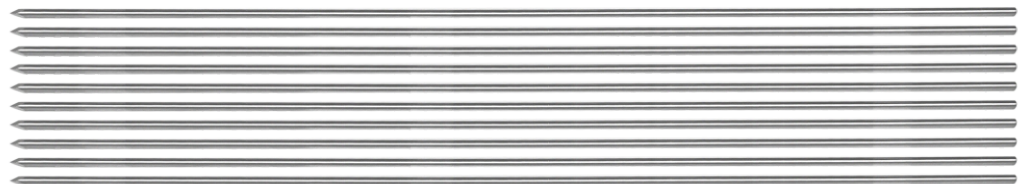

7-037-05

Guide Handle for Ø2.5mm Kirschner Wire



Instruments

7-037-06

Ratchet wrench for Nut, Hexagonal, 11mm

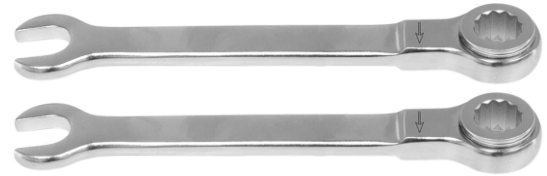

7-037-07

Hammer with Ø11mm Socket Wrench



7-037-08

Plier, Flat Nosed



7-037-09

Wire Cutter



7-037-11

Instrument Tray for Pelvic C-Clamp Instrument Set



7-037-10

Container for Pelvic C-Clamp Instrument Set

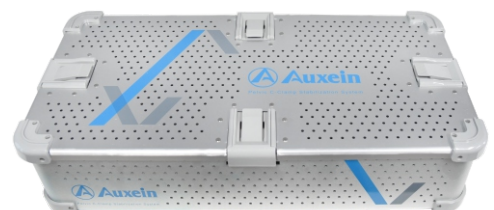

7-037 Pelvic C-Clamp Instrument set

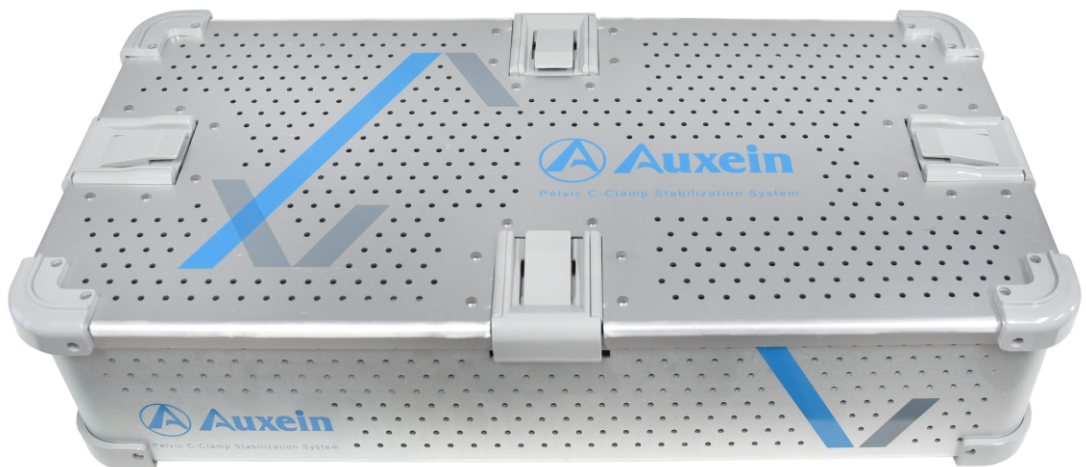
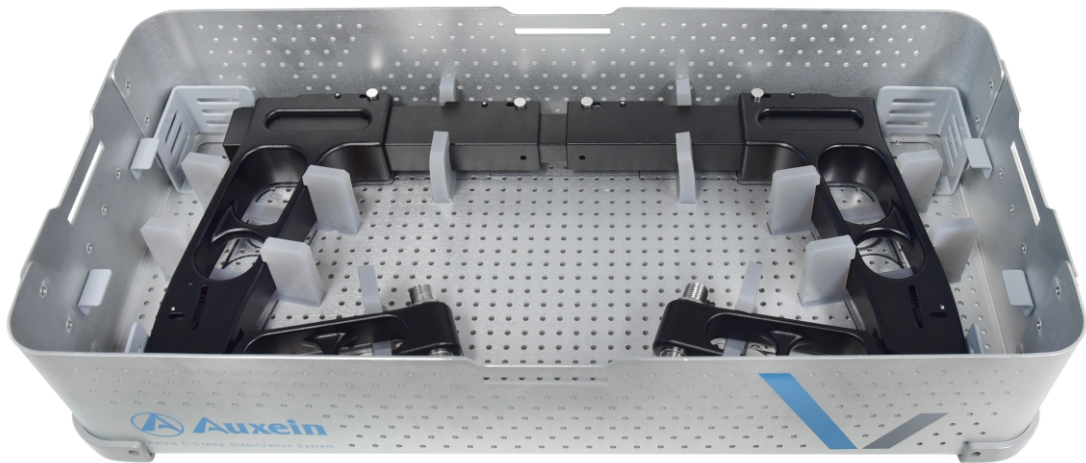
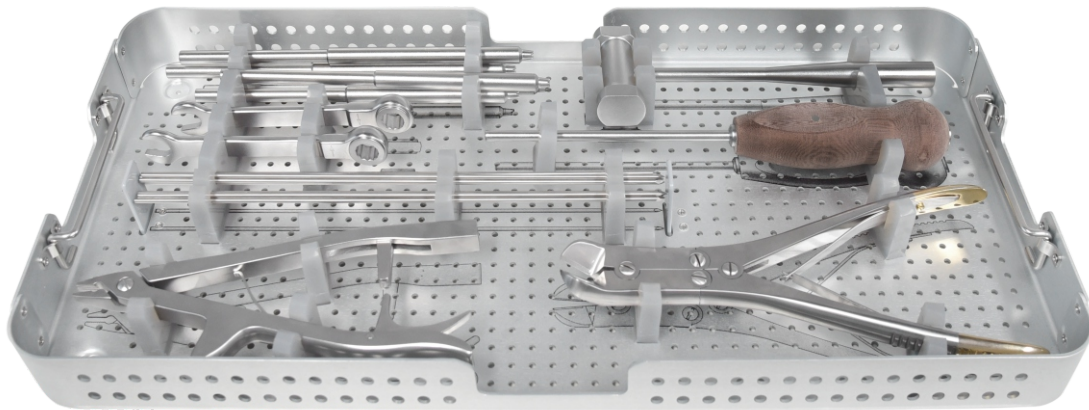

7-037 Pelvic C-Clamp Instrument set

Code	Set Consisting of	Qty.
7-037-01	Pelvic C-Clamp Arm	1
7-037-02	Nail for Pelvic C-Clamp, Cannulated, Long	2
7-037-03	Nail for Pelvic C-Clamp, Cannulated, Short	2
7-037-04	Kirschner Wire with One Sided Trocar Tip Ø2.5mm x Length 280mm	10
7-037-05	Guide Handle for Ø2.5mm Kirschner Wire	1
7-037-06	Ratchet wrench for Nut, Hexagonal, 11mm	2
7-037-07	Hammer with Ø11mm Socket Wrench	1
7-037-08	Plier, Flat Nosed	1
7-037-09	Wire Cutter	1
7-037-11	Instrument Tray for Pelvic C-Clamp Instrument Set	1
7-037-10	Container for Pelvic C-Clamp Instrument Set	1



USA

Auxein Inc.
1500 Nw 89th Court, Suite 107-108
Doral, Florida 33172
Tel: +1 305 395 6062
E Fax: +1 305 395 6262
Email: USoffice@auxein.com

MEXICO

Auxein México, S.A. de C.V.
Tepic 139 int 801, Colonia Roma Sur,
Alcaldía Cuauhtémoc, CDMX,
México, C.P. 06760
Tel: +521 55 7261 0318
Email: info@auxein.mx

INDIA

Auxein Medical Pvt. Ltd.
Plot No. 168-169-170, Phase-4,
Kundli Industrial Area,
HSIIDC, Sector-57, Sonapat - 131028, Haryana
Tel: +91 99106 43638 | Fax: +91 86077 70197
Email: info@auxein.com